

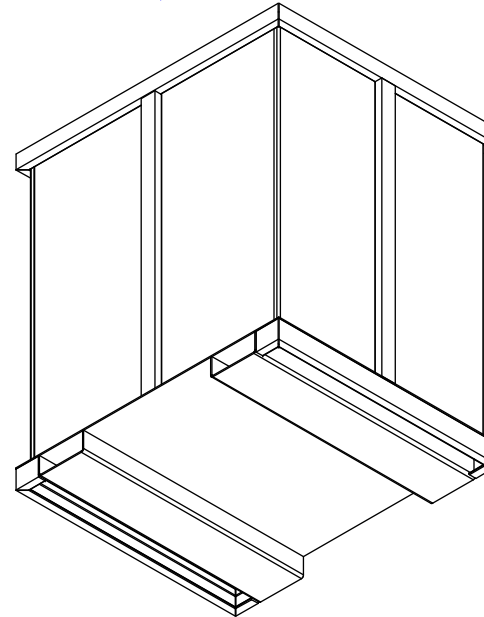

MATERIEL:	EPAISSEUR:
PREPARATION:	POIDS: 550 lbs
QUANTITE REQ. PAR CONTENANT:	

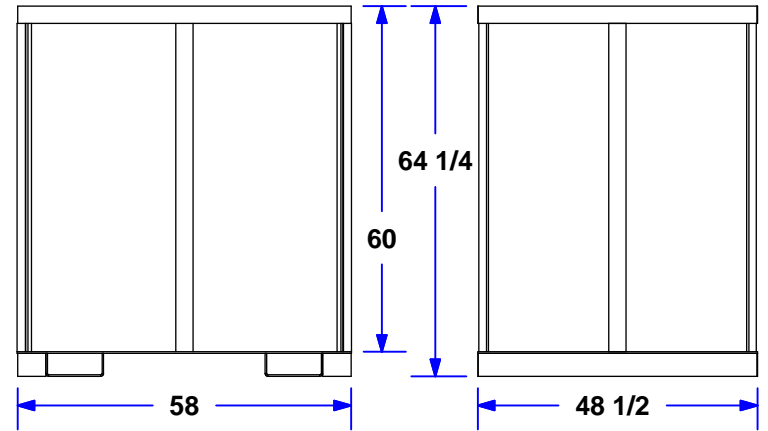
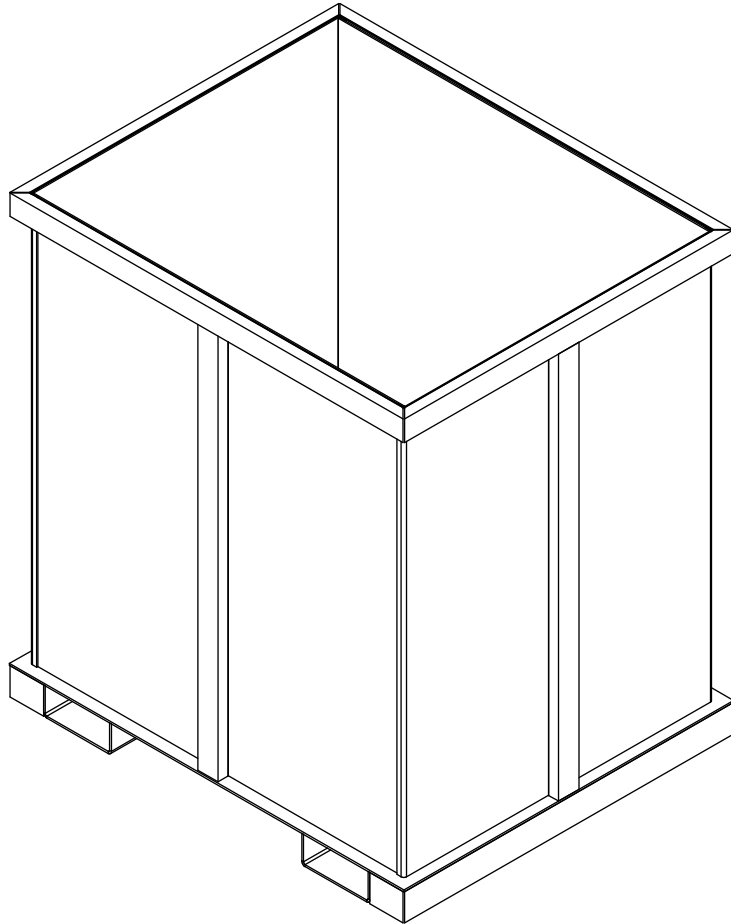

- **PLANCHER ET PATTES EN ACIER 1/4**
- **MURS EN ACIER 3/16**
- **CHANNEL DE RENFORT 3 X 5.0**
- **CHANNEL CONTOURS 3 X 5.0**
- **CHANNEL AU PLANCHER 4 X 5.4**

TOLERANCE GENERALE		 ADP CONTENEURS INC <small>manufacturier de conteneurs</small>		CE Dessin ainsi que les informations représentées ici, sont confidentiels et sont la propriété d'ADP Conteneur.	
SI NON SPECIFIE:					TITRE:
-DECIMAL	.X = 0.2" .XX = 0.06" .XXX = 0.031" TROU = 0.004"	CAISSON 60 A.I.M.		EBARBER & COUPER LES ANGLES TRANCHANTS OU PERTINENTS QUI POURRAIENT ENDOMMAGER OU CAUSER DES LESIONS	
-ANGULAIRE =	1/2°	DESSINE PAR: Mathieu M.	DATE: 2010-11-24		ECHELLE: REV.: N.T.S. 0
-RAYON PLIAGE =	1 x EPAIS. MATERIEL	VERIFIE PAR:	DATE:	PROJET:	
<input type="checkbox"/> S.I. <input checked="" type="checkbox"/> IMP.		No°D'ASSEMBLAGE:		NUMERO DE PIECE: 107-7200.iam	FORMAT A 6/6

REVISION