

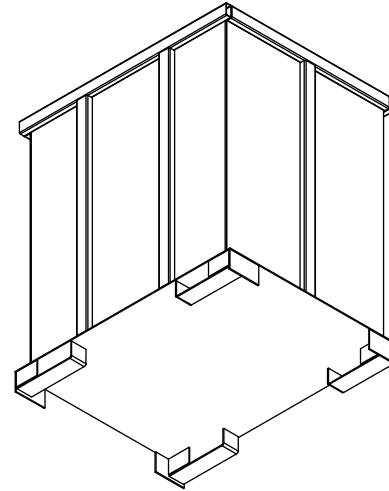

MATERIEL:	EPAISSEUR:
PREPARATION:	POIDS: 550 lbs
QUANTITE REQ. PAR CONTENANT:	

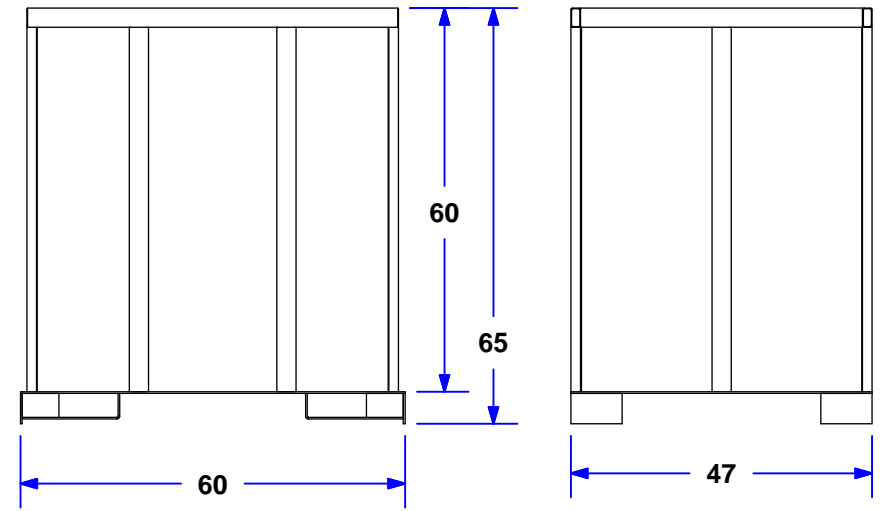
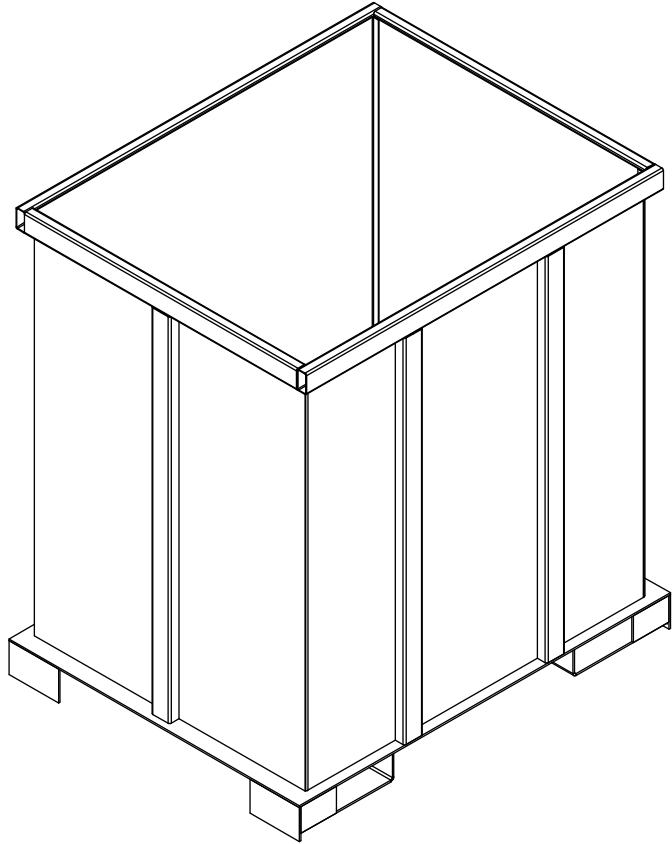

- **EMPILABLE**
- **PLANCHER EN ACIER 1/4**
- **MURS EN ACIER 1/8**
- **RENFORT DE PLANCHER 2 X 1 1/2**
- **POTEAUX DE RENFORT EXT. 3 X 1 1/2**
- **TUBE DE CONTOURS 3 X 1 1/2**

TOLERANCE GENERALE		 ADP CONTENEURS INC <small>manufacturier de conteneurs</small>		CE Dessin ainsi que les informations représentées ici, sont confidentiels et sont la propriété d'ADP Conteneur.	
SI NON SPECIFIE: -DECIMAL .X = 0.2" .XX = 0.06" .XXX = 0.031" TROU = 0.004" -ANGULAIRE = 1/2° -RAYON PLIAGE = 1 x EPAIS. MATERIEL					TITRE: CAISSON 604760 S.N.F.
<input type="checkbox"/> S.I. <input checked="" type="checkbox"/> IMP.		DESSINE PAR: Mathieu M.	DATE: 2010-10-26	ECHELLE: REV.: N.T.S. 0	EBARBER & COUPER LES ANGLES TRANCHANTS OU PERTINENTS QUI POURRAIENT ENDOMMAGER OU CAUSER DES LESIONS
<input type="checkbox"/> AMER <input type="checkbox"/> EURO		VERIFIE PAR:	DATE:	PROJET:	
REVISION		No°D'ASSEMBLAGE:		NUMERO DE PIECE: 107-7000-B.iam	FORMAT 2 A / 6